

ev¹ Series Specifications

VEHICLE

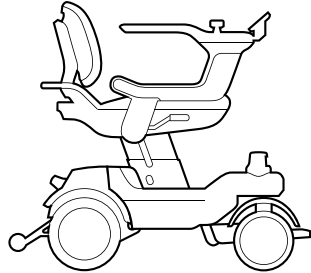

W x H x D

MIN: 58.4 x 87 x 105 cm

MAX: 66 x 98 x 105 cm

MIN: 23 x 34.3 x 41.2 inch

MAX: 26 x 38.7 x 41.2 inch

Weight

69.9 kg / 154.1 lbs ¹

MODULES

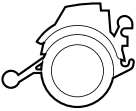
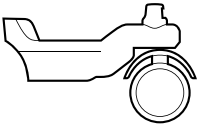
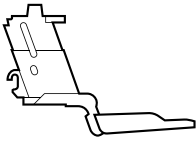
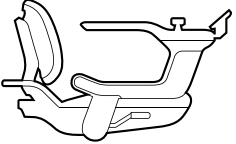
Name	Battery	Rear chassis	Front chassis	Main support	Seat
					
W x H x D	20.5 x 31 x 11 cm 8 x 12.2 x 4.3 inch	48 x 40 x 58 cm 19 x 15.7 x 23 inch	61 x 41.5 x 65 cm 24 x 16.3 x 25.6 inch	MIN: 25 x 35 x 71 cm MAX: 25 x 45 x 71 cm MIN: 9.8 x 13.8 x 28 inch MAX: 9.8 x 17.8 x 28 inch	MIN: 58 x 45.5 x 79 cm MAX: 66 x 59 x 79 cm MIN: 23 x 18 x 31.1 inch MAX: 26 x 23.2 x 31.1 inch
Weight	6 kg / 13.2 lbs ¹	19.8 kg / 43.7 lbs	18.3 kg / 40.3 lbs	7.4 kg / 16.3 lbs	18.4 kg / 40.6 lbs

¹ Flight-safe Battery is 1.7kg (3.7lbs) lighter

Disassembly

1 Long press power key to turn off the device

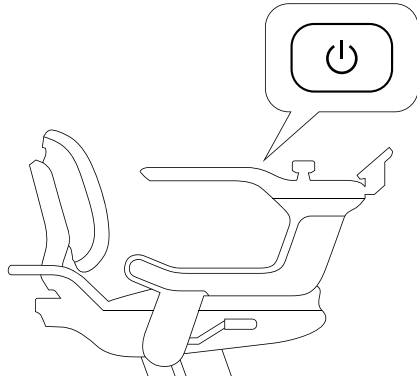

2 Install screen and sensor covers

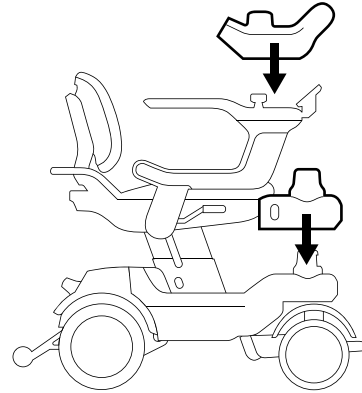

3 Unlock and remove the battery

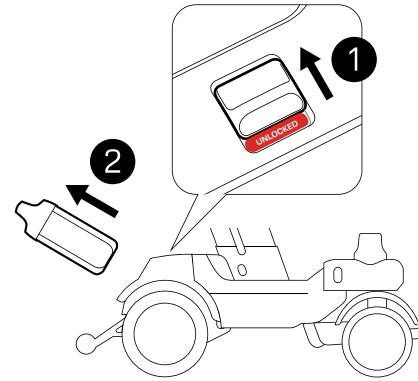

4 Remove the cushion and unlock the seat

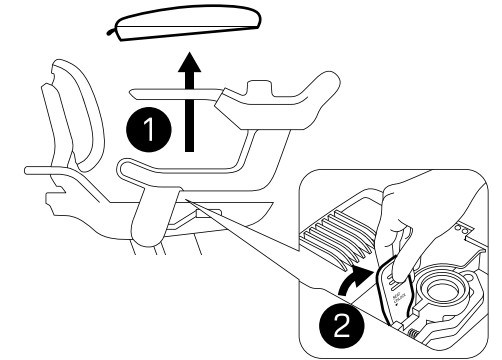

5 Lift footrest and remove the seat

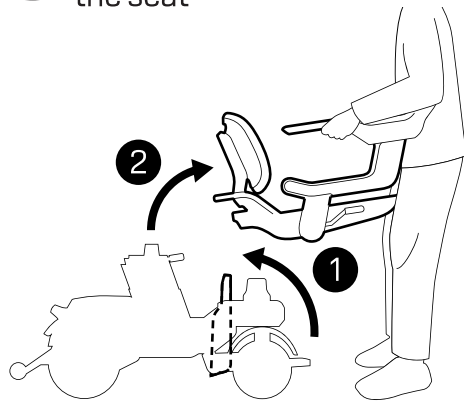

6 Unlock main support

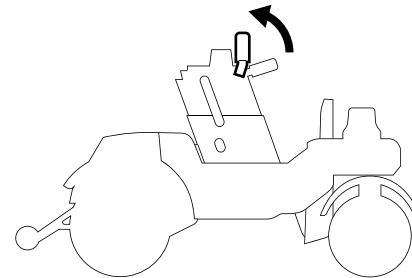

7 Remove the main support

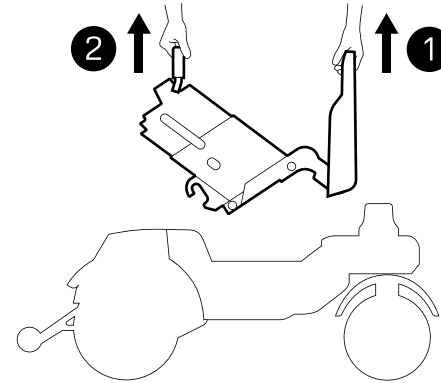

8 Separate the front chassis

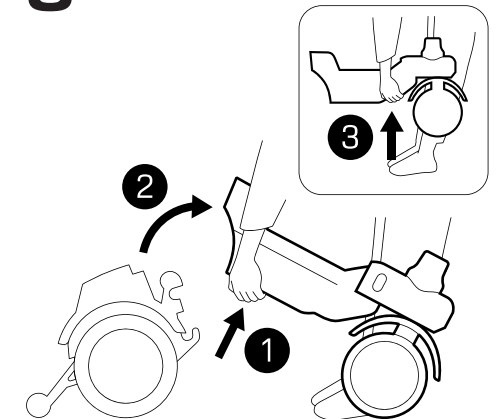

For those with limited trunk/boot space, we recommend placing the seat module on the rear seats. Avoid stacking parts on top of each other.

Assembly

1 Connect front and rear chassis

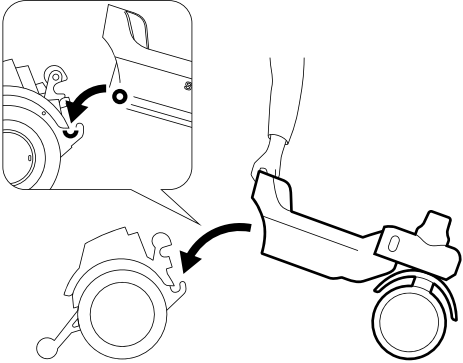

2 Hook the main support onto the chassis

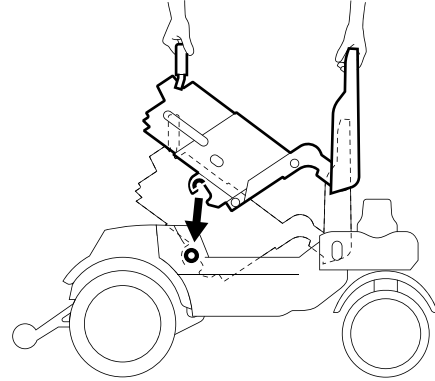

3 Rotate module and lock the handle

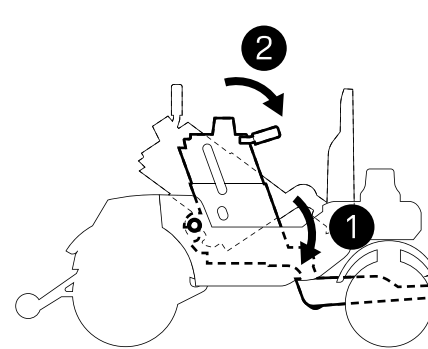

4 Secure the main support

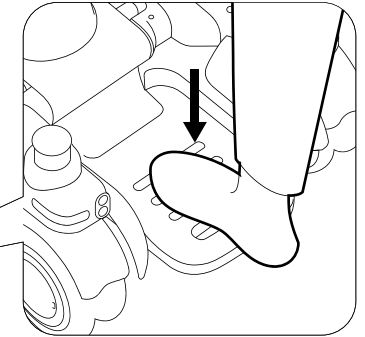

5 Remove seat cushion and unlock seat

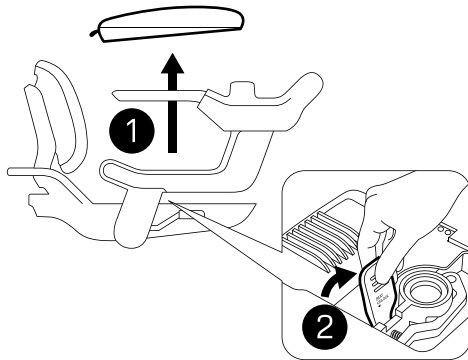

6 Install the seat onto the main support

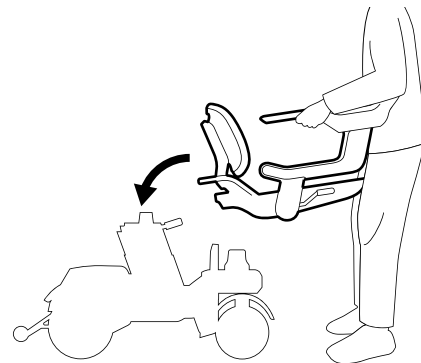

7 Lock seat and place cushion

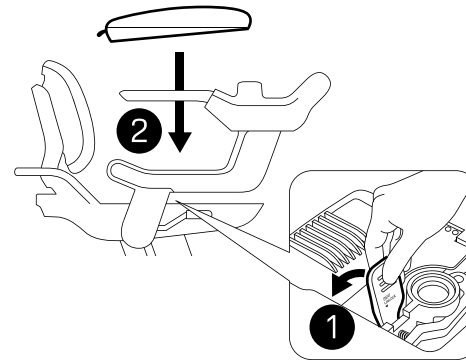

8 Insert battery and check it's locked

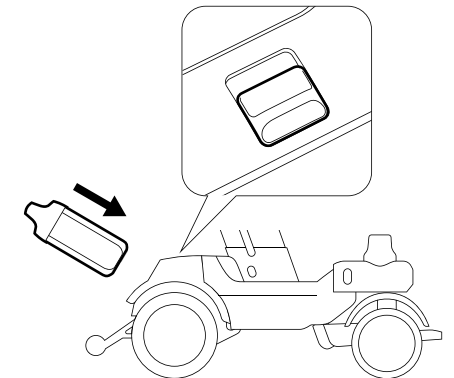

Remember to remove screen and sensor covers before driving.

Tie-down

1 Drive into the accessible van

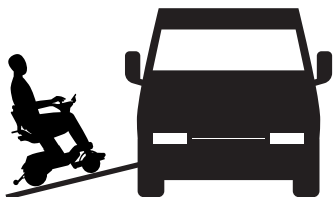

2 Transfer to passenger seat

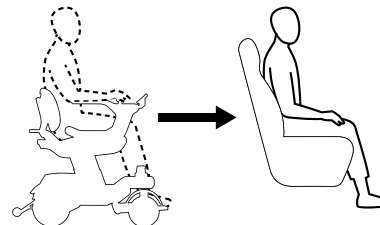

3 Hook tie-down strap onto the anti-tipping structure

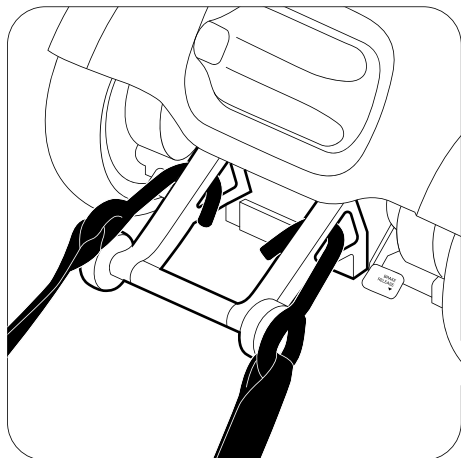

4 Hook tie-down strap under the seat

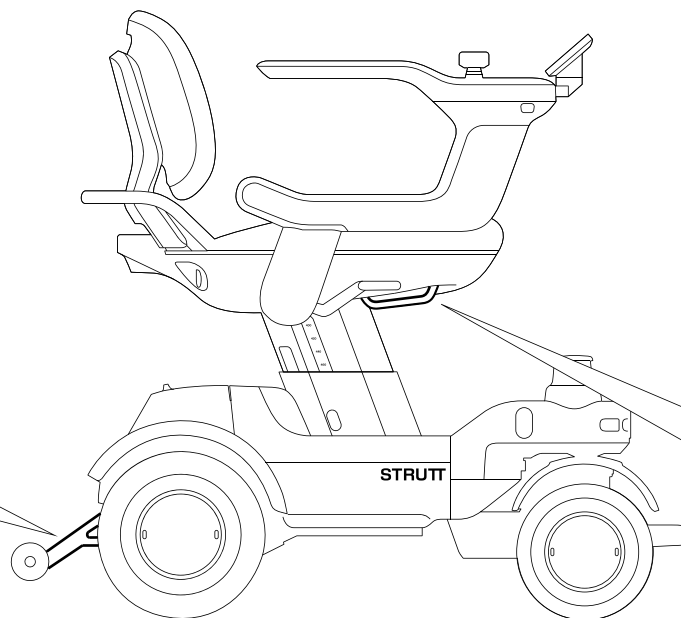
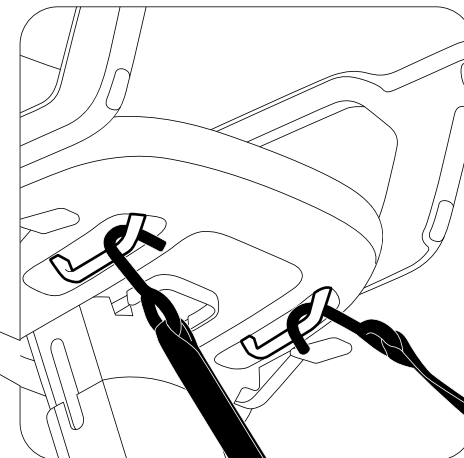

Make sure the brakes are always applied during transportation.